



**Model #AST-27**

### Standard Features - Salad Prep Table #AST-27

- Eco-friendly R290 hydrocarbon refrigerant
- Sleek, stainless steel interior and exterior
- Top holds up to (6) 1/6 size and (2) 1/9 size, 6" deep food pans, and cutting boards (sold separately)
- Insulated lid helps maintain safe product temperatures
- Single self-closing swing door with recessed handles
- Equipped with casters
- 115V, 3/7 hp, 3.6 amps
- 7.9 cu. ft.
- Conforms to NSF/ANSI STD.7.
- ETL Safety & Sanitation Listed

### Construction

|                     |                                  |
|---------------------|----------------------------------|
| Exterior Material   | 430 Stainless Steel              |
| Interior Material   | 430 Stainless Steel              |
| Insulation Material | Foamed-In-Place Polyurethane (1) |
| Shelf Size          | 23.5"W x 17.1"D                  |
| Shelf Material      | Epoxy-Coated Steel               |
| Shelf Load Capacity | 88 lbs                           |

### Cooling

|                          |             |
|--------------------------|-------------|
| Temperature Range        | 33°F - 40°F |
| Refrigerant              | R290        |
| Max. Ambient Temperature | 90°F        |
| Defrosting               | Automatic   |
| Temperature Controller   | Digital     |
| Horsepower               | 3/7         |

### Electrical

|                        |            |
|------------------------|------------|
| Voltage                | 115        |
| Amps                   | 3.6        |
| Hz                     | 60         |
| Phase                  | 1          |
| Plug Type              | NEMA-5-15P |
| Electrical Cord Length | 96"        |

### Dimensions

|                           |                                |
|---------------------------|--------------------------------|
| Exterior Dimensions       | 27.5"W x 29.5"D x 42.3"H       |
| Interior Dimensions       | 24.2"W x 19.8"D x 23.5"H       |
| Shipping Dimensions       | 31-3/4"W x 33-3/4"D x 45-1/2"H |
| Working Height            | 35-1/4"                        |
| Overall Height (Lid Open) | 47-1/4"                        |
| Shelf Dimensions          | 23.5"W x 17.1"D                |
| Net Volume                | 7.9 cu. ft.                    |
| Net Weight                | 165 lbs.                       |
| Gross Weight              | 216 lbs.                       |
| Pan Capacity              | (6) 1/6 Size + (2) 1/9 Size    |



Parts & Labor

Compressor

### PLAN VIEW

Front View

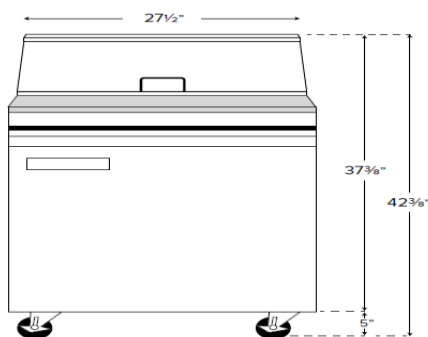

Side View

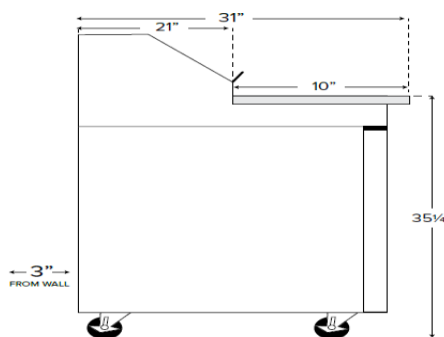

Top View

