

Gas Tube

Model AF-90



ETL Safety & Sanitation Listed



- AF-90 40 pounds gas fryer(3-tubes)
- AF-120 50 pounds gas fryer(4-tubes)
- AF-150 70 pounds gas fryer(5-tubes)

STANDARD FEATURES

- Stainless steel front and galvanized sides
- Cast iron vertical burner, each 30,000 BTU/hr
- Thermostat (200° F- 400° F) controlled
- Open S/S fryer pot with cold zone
- Standby S/S pilot for easy start
- 4 Casters, easy to move around
- Robertshaw milivolt control valve
- Prompt response thermostat ensures fast temp recovery
- 450° F hi limit for safety
- 1 1/4" full port drain valve
- S/S heater exchanger with baffle for high efficiency
- S/S hanger plate at the back
- Two baskets
- 1/2" NPT rear gas connection
- One year limited parts and labor warranty
- Gas type should be specified when confirming order

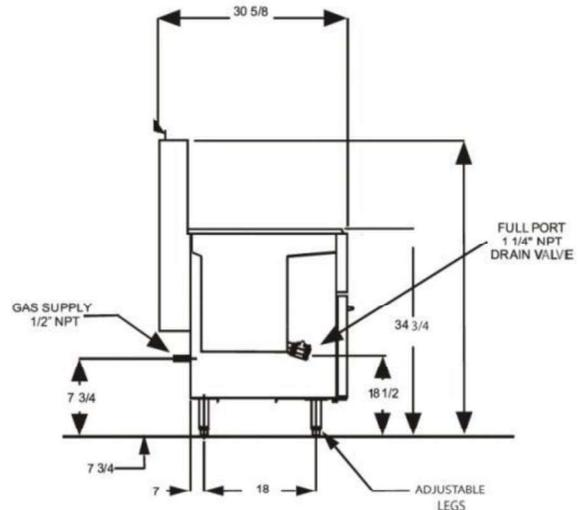
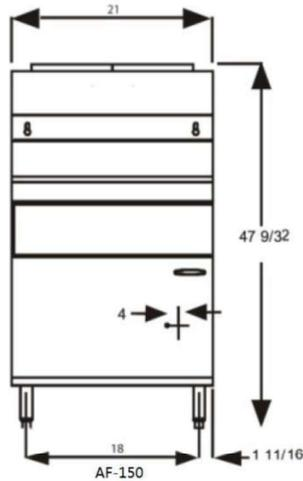
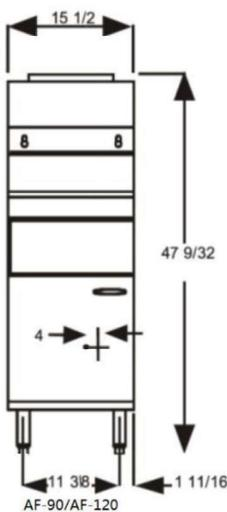

Model	Description	Capacity	Total BTU/HR	Packing Size(IN)	N/W (LB)	G/W (LB)
AF-90	Gas tube fryer	40 lbs	90,000	18x33x34	143	157
AF-120	Gas tube fryer	50 lbs	120,000	18x33x34	157	181
AF-150	Gas tube fryer	70 lbs	150,000	24x33x34	172	183